

TX BURNERS DATA

Lanemark TX series high efficiency, small diameter immersion tube tank heating systems offer end users the most cost effective method of heating process liquids which are used in many areas of industry.

Specific advantages compared with alternative tank heating methods –

- Low operating costs – operating efficiencies of $\geq 80\%$ (based on gross calorific value of gas) $\geq 90\%$ (based on net calorific value of gas)
- TX small diameter immersion tube heat exchangers occupy minimal tank space. This enables smaller tanks to be used for new plant designs and allows simple replacement of other heating systems for retrofit applications.
- TX immersion tubes can be configured in multi-pass shapes to ensure that they remain well clear of internal tank fittings or processing areas
- Tank heat input and immersion tube performance calculations are easily carried out using Lanemark's dedicated TxCalc design software
- Heat exchangers can be configured to fit rectangular tanks and horizontal or vertical cylindrical tanks utilising helical coil heat exchanger arrangements where necessary
- Induced draught combustion air arrangement allows multiple burner systems to be connected to a common flue, retaining individual burner control
- Simple heat exchanger installation requires only two pipe flange drillings, usually in one tank wall
- Firing into rubber lined or fibre glass tanks is permitted due to low initial heat exchanger surface temperatures at tank flange connection
- Operates with low gas supply pressures

TYPICAL APPLICATIONS

- **Product finishing** (metal parts, steel strip, wire products, etc.)

Pre-treatment and treatment processes including:

- Alkali / caustic degreasing
- Phosphating
- Hot water rinsing
- Aluminium etching
- Anodising
- borax and lime coatings
- Dip tanks
- Spray systems
- Hot water supply systems

- **Cleaning - industrial washing machines:**

- Plastic crate washers
- Parts washers
- Bottle washers

- **Food and Drink Production**

- Hot water tanks
- Mini brewery wort coppers
- Cleaning in place (CIP) tanks
- Food blanchers

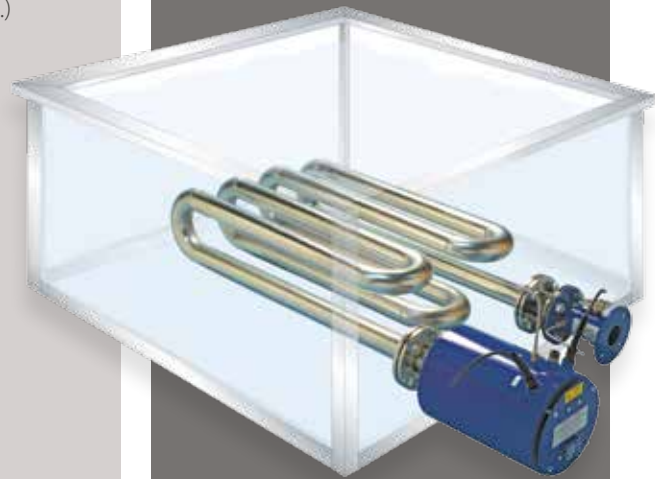

Typical system arrangement

MODEL	TUBE SIZE	MAXIMUM HEAT INPUT
TX15	1½" (40 mm)	15 - 45 kW
TX20	2" (50 mm)	20 - 80 kW
TX25E	2½" (65 mm)	35 - 140 kW
TX30	3" (75 mm)	55 - 220 kW
TX40	4" (100 mm)	100 - 400 kW
TX60	6" (150 mm)	190 - 730 kW
TX80	8" (200 mm)	300 - 1150 kW

TX Burner - Induced draught operating principle

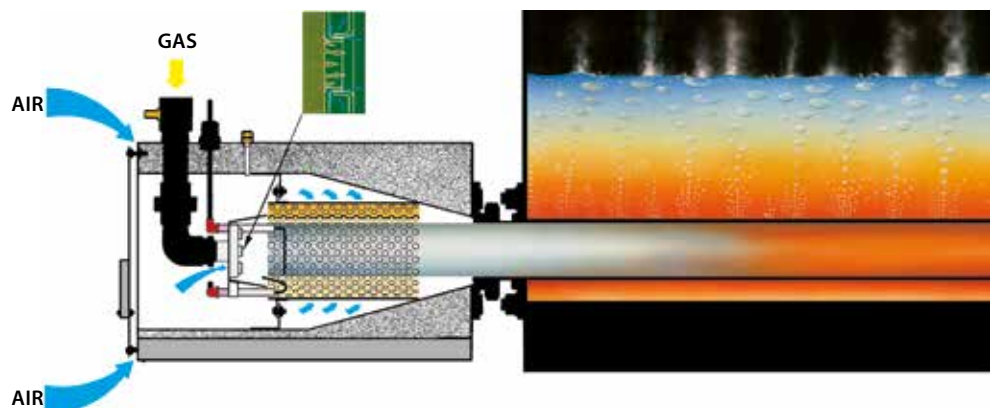

PRODUCT DESCRIPTION

A modular Lanemark TX immersion tube burner system includes a cylindrical burner assembly built to withstand typical tank heating operating environments, a compact monoblock gas valve train, burner controls mounted in a protective control box (which can include a digital temperature controller), exhaust damper and an exhaust fan which can be coupled to multiple TX burner installations.

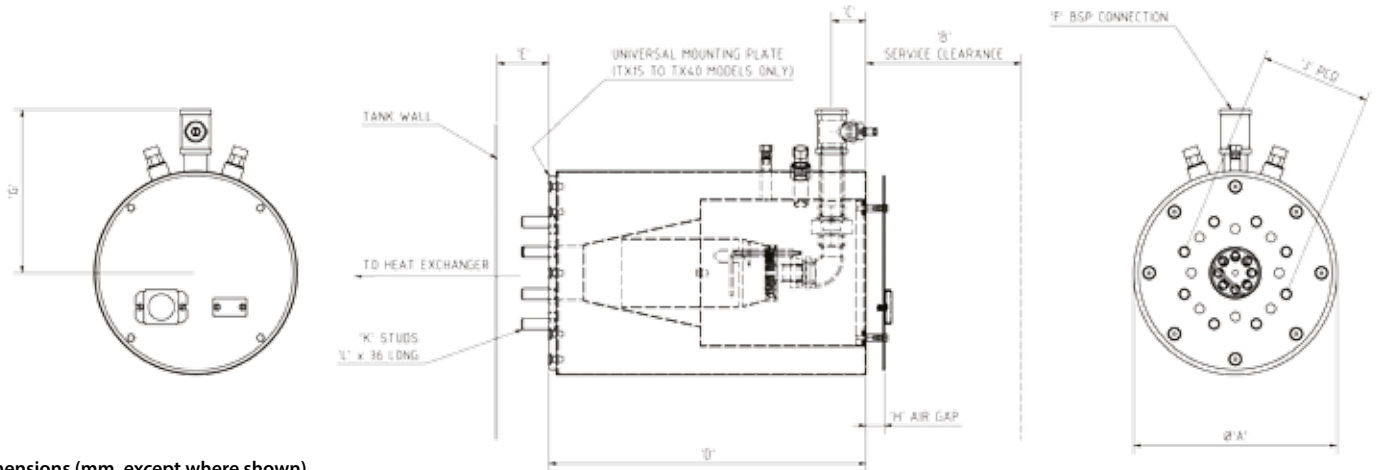

Dimensions (mm, except where shown)

MODEL	TX15	TX20	TX25E	TX30	TX40	TX60	TX80
A mm	220	220	295	295	295	405	405
B mm	150	150	225	225	300	320	320
C mm	40	40	50	50	50	120	60
D mm	305	305	450	450	500	625	625
E mm	75	75	75	75	100	100	100
F	½"	½"	1"	1"	1"	1½"	2"
G mm	160	160	210	210	230	305	355
H mm	12	12	25	25	25	35	35

DIN PN16 FLANGE CONNECTION

MODEL	TX15	TX20	TX25E	TX30	TX40	TX60	TX80
J mm	110	125	146	160	180	240	295
K qty	4	4	4	8	8	8	12
L size	M16	M16	M16	M16	M16	M20	M20

BS TABLE 'D' OR 'E' FLANGE CONNECTION

MODEL	TX15	TX20	TX25E	TX30	TX40	TX60	TX80
J mm	98	114	127	146	178	235	N / A
K qty	4	4	4	4	4	8	N / A
L size	M12	M16	M16	M16	M16	M16	N / A

SPECIFICATIONS	STANDARD EQUIPMENT	OPTIONS
Fuels	Natural gas	Propane
Control voltages	230 V / 1ph / 50 Hz	110 V / 1ph / 50-60 Hz
Exhaust fan electrical supplies	400 V / 3ph / 50 Hz	230 V / 1ph / 50 Hz or 460 V / 3ph / 60 Hz
Flame sensing	Flame electrode	UV scanner
Heat output control options	On / off or High / low	Modulating (gas and air)

Lanemark TX burner gas valve train and control panel assemblies are pre-wired / tested prior to despatch and conform with relevant sections of European Standard EN 746 Part 2 or NFPA 86 for US applications.



All TX burners benefit from Lanemark's BurnerCare customer support. BurnerCare services can include burner system installation, commissioning / start-up, system training, regular servicing and the supply of spare parts. BurnerCare can provide a service agreement plan incorporating a rapid response facility individually designed to ensure the continued, reliable operation of Lanemark equipment worldwide.



All illustrations are for guidance only. For reasons of continuous development, Lanemark Combustion Engineering Limited reserves the right to alter specifications without prior notice.



Registered Address: Lanemark House, Whitacre Road, Nuneaton, Warwickshire, UK, CV11 6BW
 T: +44 (0) 24 7635 2000 F: +44 (0) 24 7634 1166 E: info@lanemark.com W: www.lanemark.com

Company Registration No. 1561589. VAT No. GB 307 5790 48.

Place of Registration: England and Wales. Directors: P.R. Collier, J.S. Foster, A.E. Thompson.