

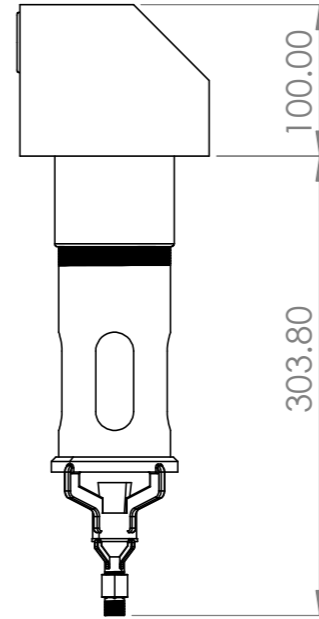

[DVM-2.5] MULTI-STAGE VENTURI GAS MIXER 2.5" SUS 316, 1/4" NPT

[NOZ1] BRASS NOZZLE NO.1



Model : MFB750-9-TX  
 Design power input : 38 kW  
 Heating area : 0.002 sq.m  
 Heating mode : Blueflame  
 Flame mode : SPEAR-BLUE® FLAME  
 The major part of the convective energy released when using blue flame mode on high porous metal fiber produces a distant, spear-shaped flame. PP Systems' special design, with an infrared ring surrounding the base achieves wider turn-down ratio and allow for better resistance in high wind operation.

*This drawing is the property of PP Systems. Any complete or partial reproduction is forbidden.*

 <b>PYRO precision</b> <small>advanced surface combustion technologies</small>	ALL DIMENSIONS ARE IN MILLIMETERS		TITLE: <b>Metal Fiber Burner</b>	
	Drawn	P.JATURONK	SIGNATURE	<i>Jaturonk</i>
	Improvement	P.SATIT	SIGNATURE	<i>Satit P.</i>
	DATE: 2/3/2021	REVISION: 0	DWG NO.	<b>MFB750-9-TX-D001</b>
WEIGHT:			SCALE:1:5	SHEET 1 OF 1

A3