

Gas Supply HP System
Detail Sheet 5

HD600x6 Infrared Burner System
Detail Sheet 3

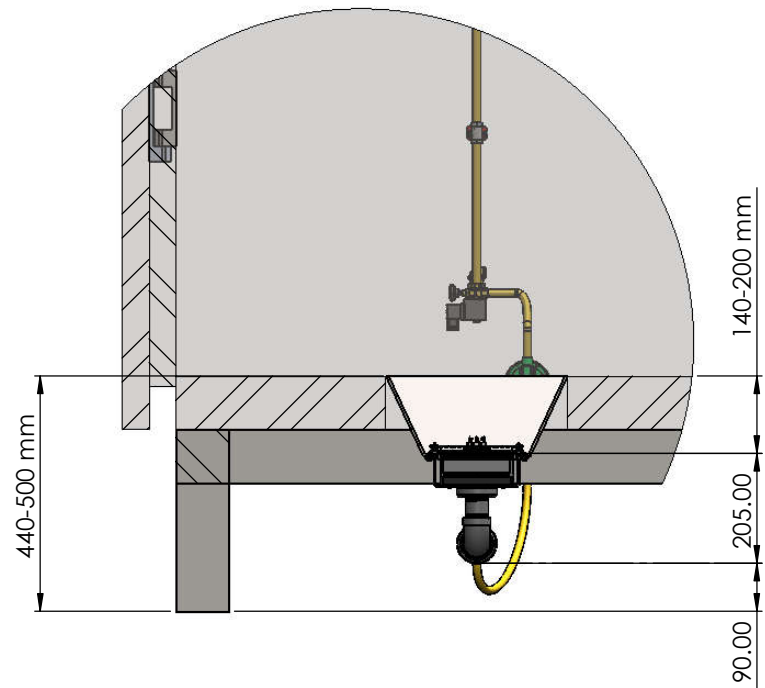

ALL DIMENSIONS ARE IN MILLIMETERS			TITLE:	
NAME	SIGNATURE		Metal Fiber Burner	
Drawn	P.JATURONK	Jaturonk		
Improvement	P.SATIT	Satit P.	DWG NO.	HW-B-ND-CIR-D001 A3
DATE:	17-Apr-20	REVISION:	0	
WEIGHT:	SCALE:1:100		SHEET 1 OF 5	

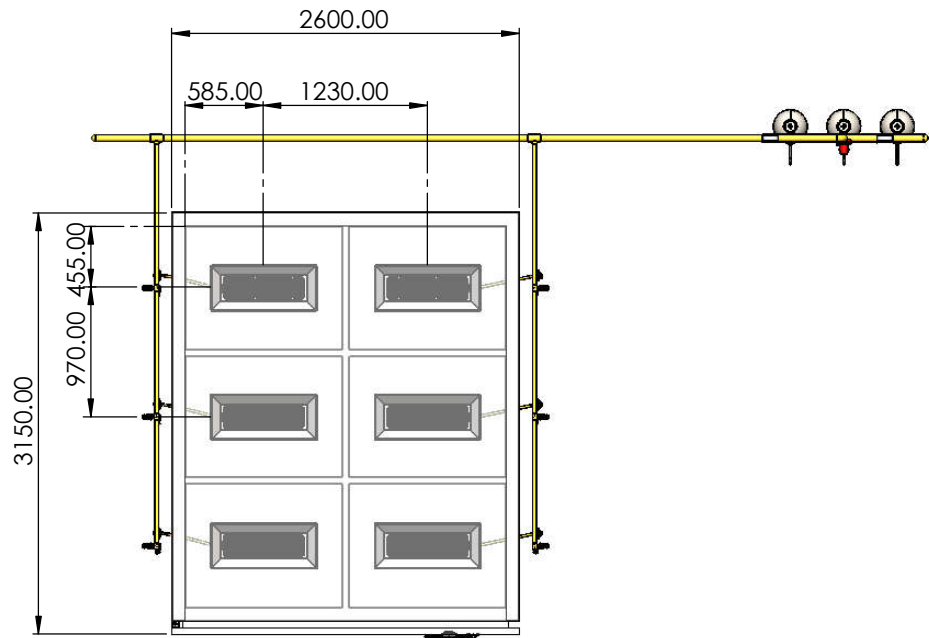

DETAIL G
SCALE 1 : 10

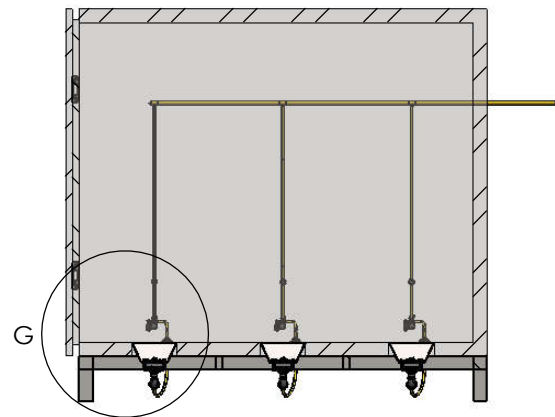
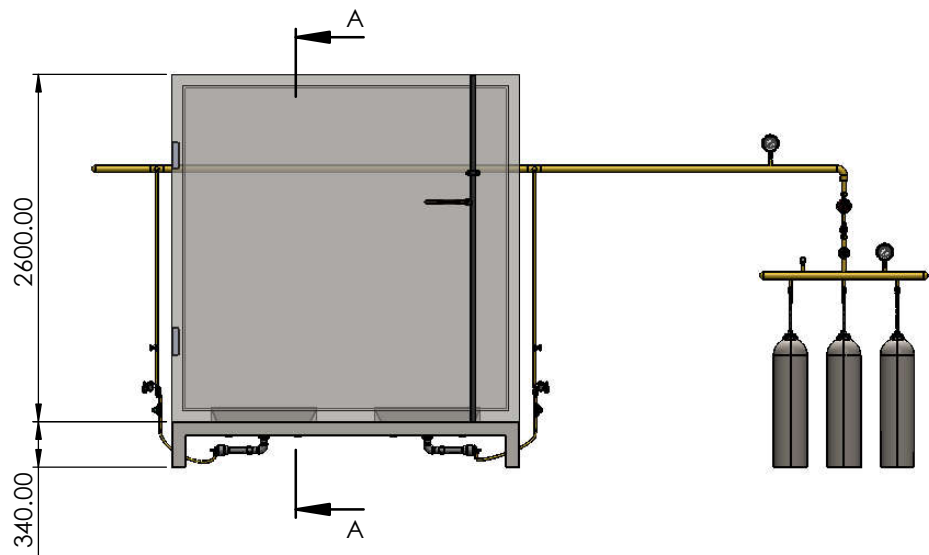

SECTION A-A
SCALE 1 : 40



ALL DIMENSIONS ARE IN MILLIMETERS			TITLE:	
Drawn	NAME P.JATURONK	SIGNATURE <i>Jaturonk</i>	Metal Fiber Burner	
Improvement	P.SATIT	<i>Satit P.</i>	DWG NO.	HW-B-ND-CIR-D001 A3
DATE: 17-Apr-20	REVISION: 0	WEIGHT:	SCALE:1:100	SHEET 2 OF 5

8 7 6 5 4 3 2 1

F

F

E

E

D

D

C

C

B

B

A

A

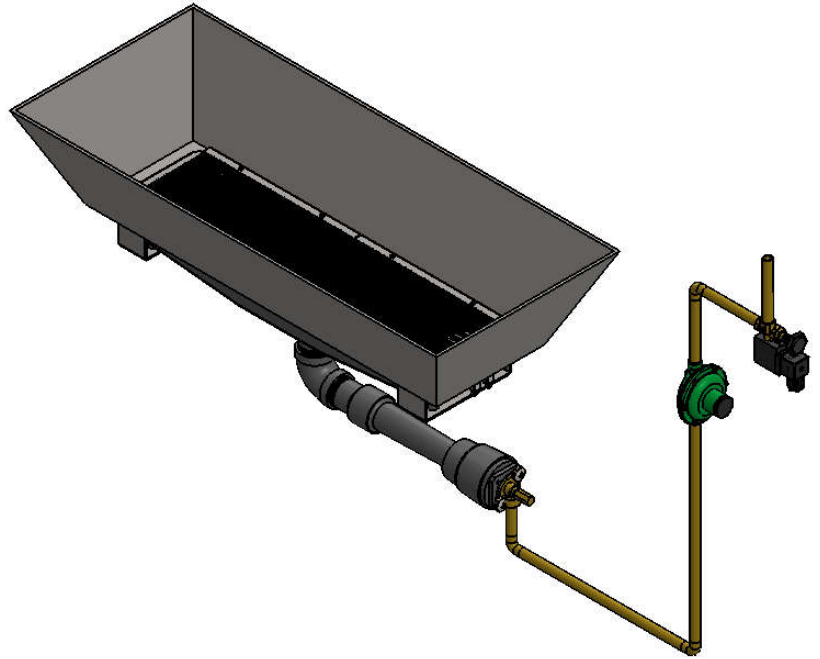
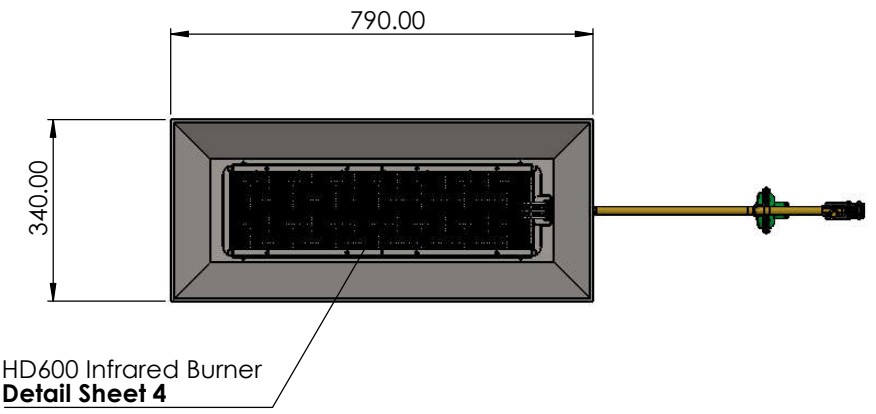

[ZCQ-01B] Flow Control Brass Solenoid Valve Gas FT-1/4", 220VAC, 0-8 bar, IP65

[KRR-LPR-1/4] Low Pressure Regulator for LPG, Output 40-80mbar, Size 1/4"

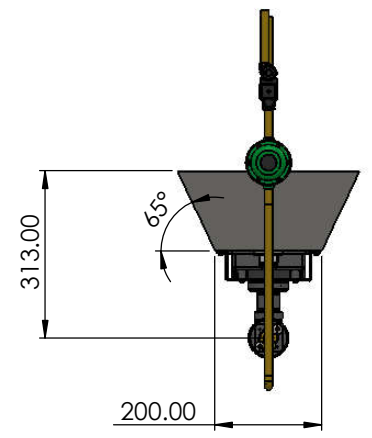
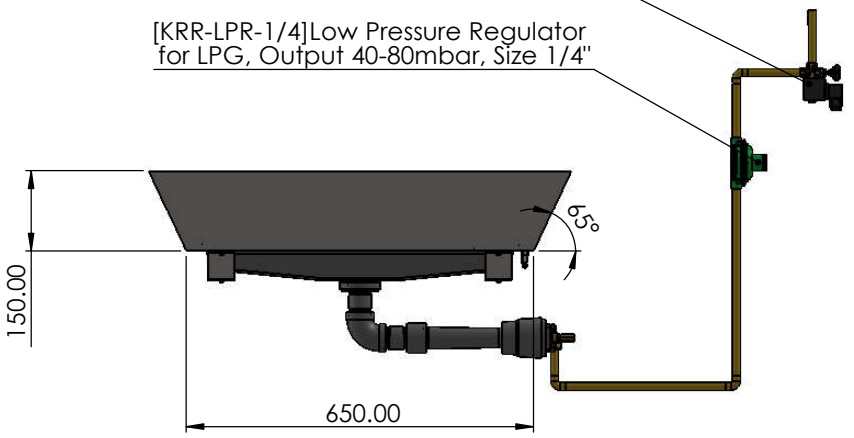

ALL DIMENSIONS ARE IN MILLIMETERS			TITLE:	
NAME		SIGNATURE		Metal Fiber Burner
Drawn	P.JATURONK	<i>Jaturonk</i>		
IMPROVEMENT		SIGNATURE		DWG NO. HW-B-ND-CIR-D001 A3
Improvement	P.SATIT	<i>Satit P.</i>		
DATE: 17-Apr-20		REVISION: 0		SCALE: 1:10
WEIGHT:		SHEET 3 OF 5		

8 7 6 5 4 3 2 1

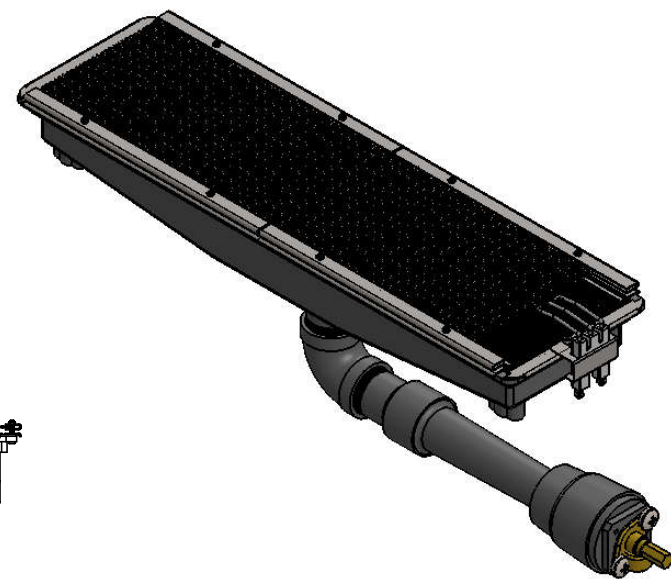
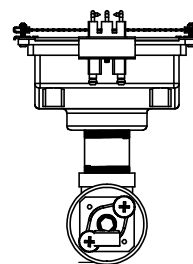
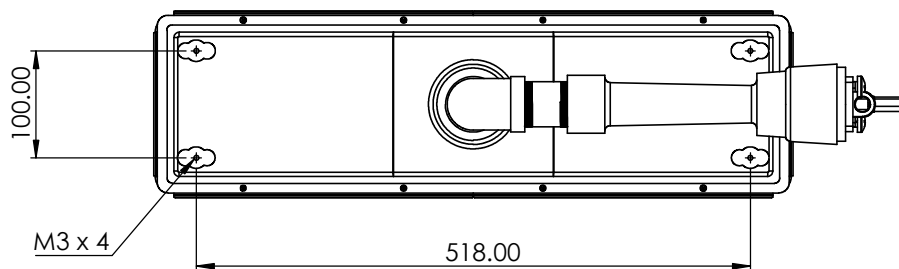
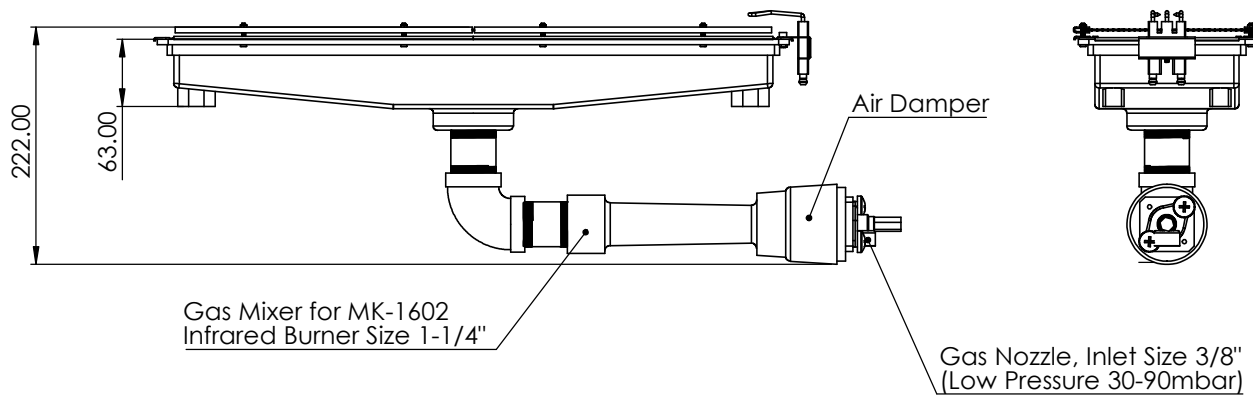
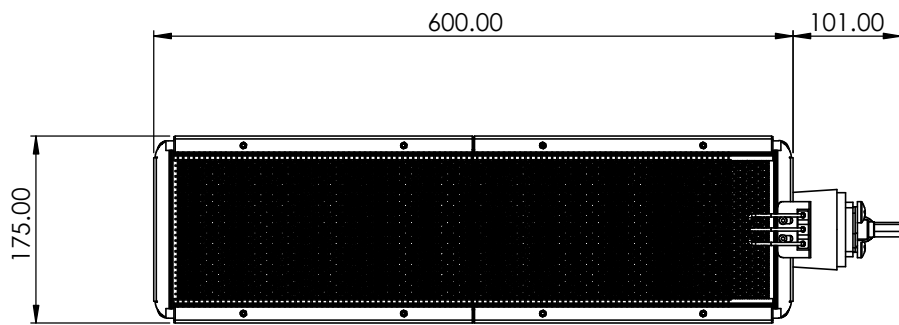

Model	HD600
Power	9.4 kW
Body Construction	Cas Steel
No of Plaque	(6) 135mm x 93mm
Gas Type	LPG
Gas Consume	0.68 kg/hr
Supply Pressure	30-90 mbar
Dimension in mm	L600 x W175 x H220
Weight	10.5 kg

Note : This drawing is the property of PP Systems. Any complete or partial reproduction, or any transmission to third party without PP Systems authorization is forbidden.



ALL DIMENSIONS ARE IN MILLIMETERS			TITLE:	
NAME	SIGNATURE		Metal Fiber Burner	
Drawn	P.JATURONK	Jaturonk		
Improvement	P.SATIT	Satit P.	DWG NO.	HW-B-ND-CIR-D001 A3
DATE: 17-Apr-20	REVISION: 1		SCALE:1:5	
WEIGHT:			SHEET 4 OF 5	

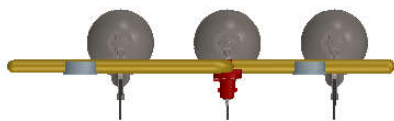

[64/35] HIGH P.REGULATOR 5-35 PSI (0.34-2.4 BAR),
1/2" NPT. PROPANE CAPACITY 1,055kW "FISHER"

[6213] SOLENOID VALVE 2/2, SIZE 1/2"
COIL 230V/50Hz - ORIFICE 13MM "BURKERT"

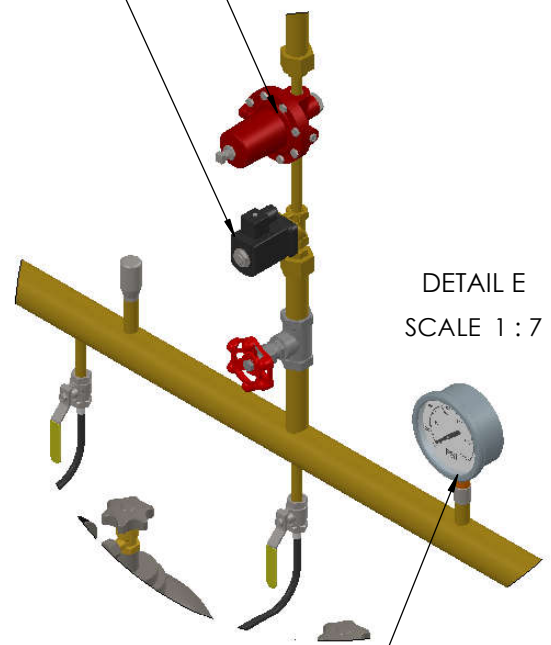
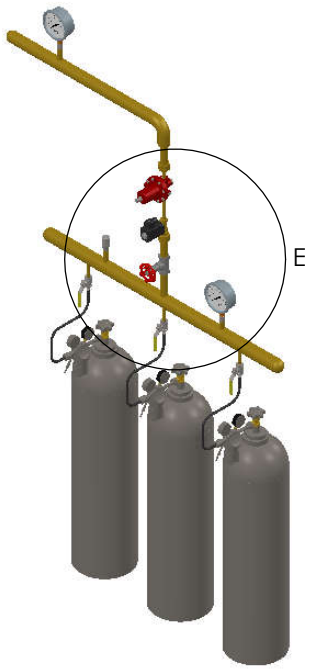
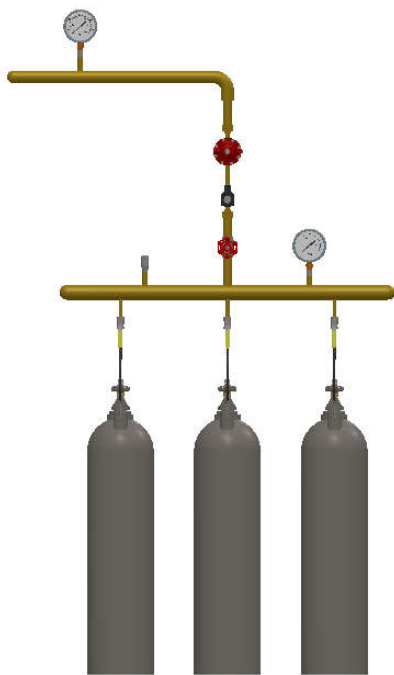

DETAIL E
SCALE 1 : 7

[DS63A-0-25] P/GAUGE 0-25BAR 1/4"NPT, ITALY "NUOVA FIMA"

Note : This drawing is the property of PP Systems. Any complete or partial reproduction, or any transmission to third party without PP Systems authorization is forbidden.



ALL DIMENSIONS ARE IN MILLIMETERS			TITLE:	
NAME		SIGNATURE		Metal Fiber Burner
Drawn	P.JATURONK	Jaturonk		
Improvement	P.SATIT	Satit P.		DWG NO.
DATE: 17-Apr-20	REVISION: 0	HW-B-ND-CIR-D001		A3
WEIGHT:		SCALE:1:50		SHEET 5 OF 5